

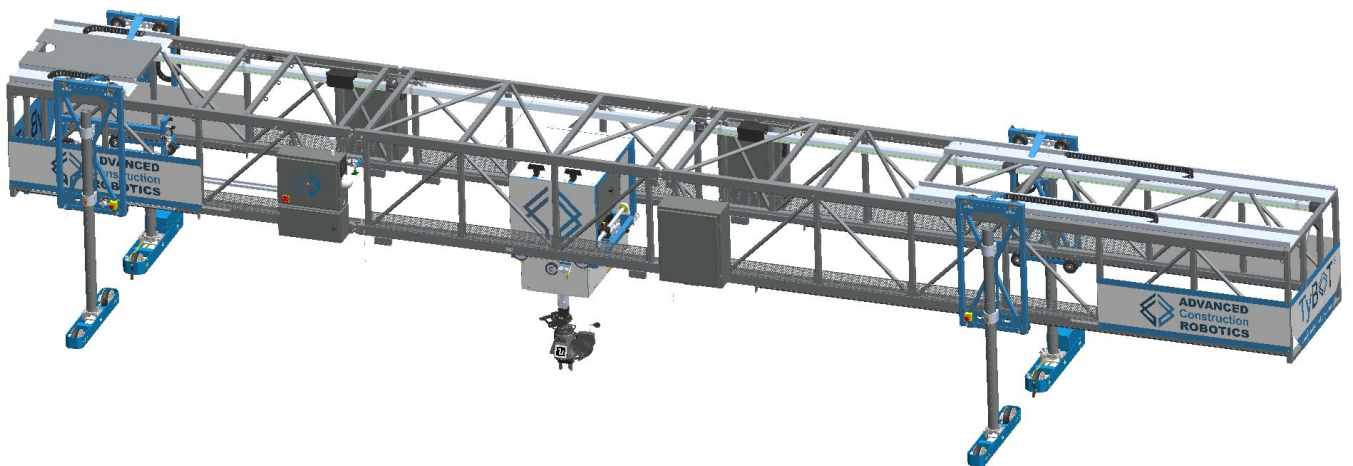

**ADVANCED
Construction
ROBOTICS**

TyBOT[®]

REBAR TYING ROBOT





Automated Rebar Installation

TyBOT takes care of the repetitive, backbreaking task of tying rebar while your crew focuses on more complex work. TyBOT streamlines and safely accelerates horizontal rebar installation by autonomously tying rebar intersections with 99% accuracy.

Key Features

- No programming, pre-mapping, or BIM input
- Working within 2 hours upon project arrival
- Self-locates, self-positions, and self-ties bulk rebar intersections (33%, 50%, or 100% coverage)
- Active tie rate of 1,200+ per hour
- Ties day or night, rain or shine
- Travels on existing screed rail or edge forms
- Expandable widths from 11' to 117'

Benefits

Enhanced Productivity

Augment existing crews by using technology to fill in skilled labor gaps due to worker shortages; increasing output and providing scalable capacity to perform more projects.



Increased Safety

Relieve workers from injury-prone tasks and extend their career longevity. Jobsite robots assist with work items that frequently cause repetitive stress and other common lost-time injuries, minimizing safety incidents.

Reduced Schedule Risk

Minimize delays, liquidated damages and site operating costs. Jobsite robotics are designed to work day or night, rain or shine, facilitating project critical path acceleration.



Improved Consistency

Improve consistency with predictable production rates and real-time feedback on accuracy. Construction technology provides reliable and steady output, minimizing overtime volatility.



Equipment Overview

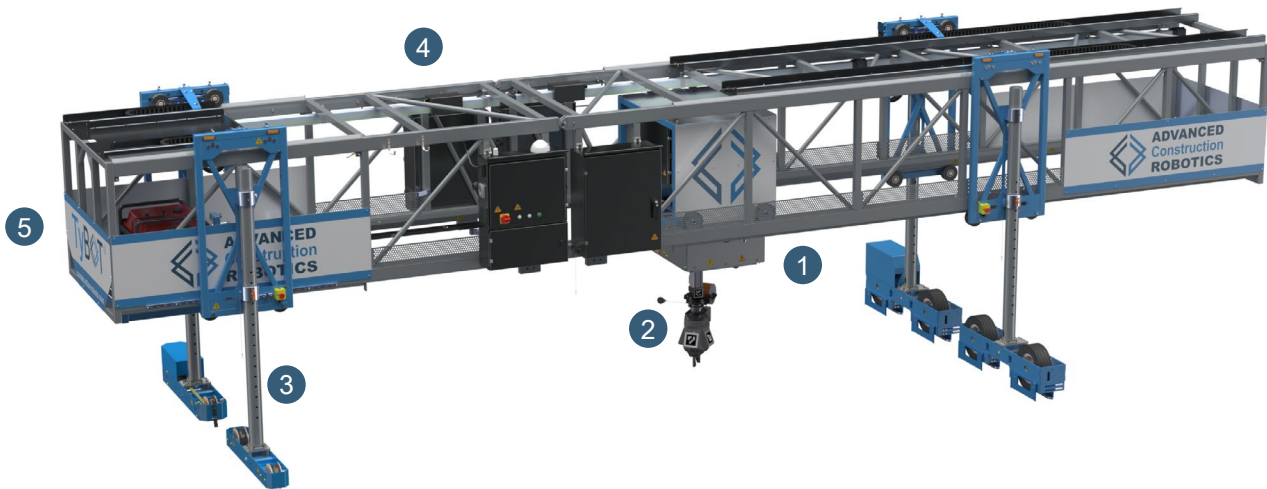

1 Tram

Houses the core components of TyBOT's see, think, and act capabilities featuring a dual camera system that self-identifies rebar intersections. It moves along a fully integrated track system, with the Tie Module autonomously positioned.

2 Tie Module

Autonomously ties rebar intersections at 100%, 50%, or 33% coverage for bottom & top mats.

3 Legs and Bogies

Adjustable Gantry Legs accommodate varying widths, heights, cross-slopes, grades, and skews. Bogies ride on existing screed rail, Porta-Rails or directly on edge forms.

4 Gantry System

Durable, lightweight, and easily transportable, load requirements are less than finishing machines. Integrated storage included for Tie Module & Wire Spools.

5 Power

Predator 8750 Inverter Generator that continuously operates for up to 10 hours without refueling. Generator sits on a sliding generator platform in the Gantry for easy access.

SCANRECO Belly Box

Mobile robot interface unit allows communication between robot and supervisor. Contains safety controls, operating mode selections, and real-time reporting diagnostics and error feedback. Features a 12+ hour battery life and color sunlight readable screen. Translations for Spanish and French available.





TyBOT[®] TyBOT Specifications

Rebar Applications

Horizontal Cast-In Place (with the exception of Truss Shaped Rebar)

Epoxy Coated, Black Bar, Galvanized, Stainless, Fiberglass

Rebar Tying

Tie Wire Type:	Plastic Coating 16.5 AWG Black Annealed 16 AWG
Tie Wire Spool Capacity:	15 LBS (6.8 KG), Estimated 3,000 Ties
Tie Type/Pattern Modes:	Single Snap 100% (every intersection), 50% (alternate intersections), or 33% (every third intersection)
Active Tie Rate:	MIN: 900 Ties per Hour OBSERVED: 1,200+ Ties per Hour
Tie Tension Adjustment:	8 Settings

Operational Data

Startup Time:	< 2 MIN
Operating Temperature (Min/Max):	32 - 104 F (0 - 40 C)
Bar Grid Spacing:	MIN: 3.0 IN x 3.0 IN (7.6 CM x 7.6 CM) MAX: 12 IN x 12 IN (30.4 CM x 30.4 CM)
Bar Intersection Sizes:	MIN: #4 with #4 (1.000 IN / 2.5 CM) = #8 combined bar size MAX: #8 with #9 (2.125 IN / 5.4 CM) = #17 combined bar size
Bar Chair Height:	MIN BOTTOM MAT: 1.0 IN (2.5 CM) MIN TOP MAT: 1.5 IN (3.8 CM) MAX BOTH MATS: 4 IN (10.1 CM)
Crown Reach (Min/Max):	0 - 17 IN (0 – 43.1 CM) at 117 FT (35.6 M)
Screed Rail Height from Bottom Mat:	MIN: 12 IN (30.4 CM) MAX: 54 IN (137.1 CM)
Cross Slope Grade:	MAX: 6% (<70 FT (21.3 M) Screed Rail Width) 4% (>70 FT (21.3 M) Screed Rail Width)
Max Break in Cross Slope:	4%
Max Grade Differential:	1% up to 40FT (12.2 M) Screed Rail Width 2% above 40FT (12.2 M) Screed Rail Width
TyBOT Skew Angle:	MAX: 30 DEGREES

Travel Path

Longitudinal Travel Speed:	MAX: 0.4 FT/Sec (2.7 MPH) 0.12M/Sec (4.4 KPH)
Screed Rail to Rebar Mat (Min/Max):	0 - 42 IN (0 – 107 CM)
Rail Radius:	MIN: 275 FT (84 M)
Screed Rail Type:	2 IN (5.08 CM) Nominal Pipe (Round) or 2x4 to 2x8 Dimensional Lumber
Longitudinal Grade:	MAX: 6% (<70 FT (21.3 M) Screed Rail Width) 4% (>70 FT (21.3 M) Screed Rail Width)



Power

Power:	7,000 Watts
Voltage:	240 VAC
Fuel Consumption (Full Load):	0.95 GPH (3.6 L/HR)

Unit Measurements

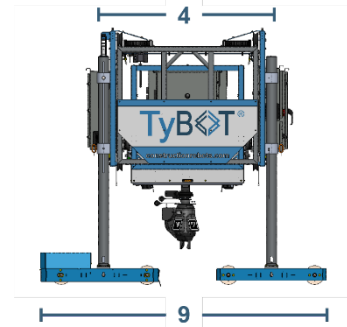
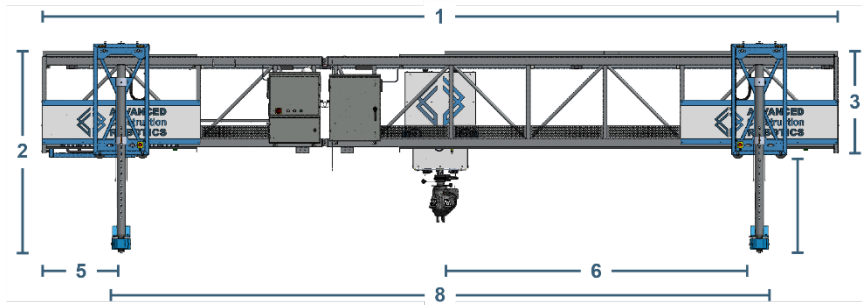

Pictured: Base Unit

1. Unit Width (Truss end-to-end width):	Base: 29.6 FT (9 M)*
	Standard: 64 FT (19.5 M) Full: 117 FT (35.6 M)
*Width will vary based on configuration	
2. Shipping Height (w/o Tie Module):	MIN: 91 IN (231.1 CM)
	MAX: 104 IN (264.1 CM)
3. Truss Height:	1M-3M Middle: 45 IN (114.3 CM)
	6M Middle: 66 IN (167.6 CM)
4. Truss Depth:	54 IN (137.1 CM)
5. Min Overhang:	18 IN (45.7 CM)
6. TyBOT Work Area:	18 IN (45.7 CM) from Screed Rail
7. Leg Height Adjustment:	MAX: 42 IN (106.6 CM) using 3 IN (7.6 CM) Increments
8. Screed Rail Width:	MIN: 9.5 FT (2.9 M)
	MAX: 118 FT (36 M)
9. Outside Bogie Wheel Base:	110 IN (279.4 CM)
Inboard Bogie Clearance from Rail Center:	MIN: 4.5 IN (11.4 CM) BILATERAL
Tie Module Transversal Clearance:	MIN: 3 IN (7.62 CM)
Unit Weight:	Base: 4,050 LBS (1,836 KG)
Bogie Wheel Load:	MAX: 1,500 LBS (680.4 KG) per Wheel at 33 IN (83.8 CM) Spacing



Machines That See, Think, and Act

How TyBOT Works

TyBOT uses its two cameras to navigate and tie with impressive precision, continuously scanning as it works to map and learn its surroundings. It identifies good, bad, and extra intersections, keeping track of ties and following the correct pattern with an accuracy rate of 99%. Throughout the shift, TyBOT remembers its progress—even after a Tie Module replacement—adapting to changes in bar densities and spacing while skillfully ignoring out-of-pattern elements like extra bars or misplaced chairs. Once it completes an area, TyBOT notifies the Robot Supervisor™ and seamlessly moves forward to continue operations.

How You Communicate with TyBOT

TyBOT's Belly Box is designed for seamless user experience, featuring built-in control references and help buttons that display relevant controls for the current screen and mode, keeping supervisors informed at all times. The fault management system provides real-time prompts to help troubleshoot issues quickly, minimizing downtime. Plus, with proactive fault reporting and a message center, supervisors receive instant feedback for faster phone support, ensuring smooth and uninterrupted supervision.

? **Is it safe to move the gantry forward?**
Check for any obstacles on or around the rails. If it is safe for the gantry to move, select proceed.

PROCEED

MANUAL | **TYING**

33% Coverage Mode | **6,477** Tie Count

Bottom Mat Level | **727** Production Rate | **81 ft** Linear Progress

Fuel: 86% | 63% |

SETTINGS

<input type="checkbox"/> Reverse Operations	OFF
<input type="checkbox"/> Tie Tension	2/5
<input type="checkbox"/> Z Force	1/8
<input type="checkbox"/> Gantry Differential Control	OFF
<input checked="" type="checkbox"/> Obstacle Avoidance	ON

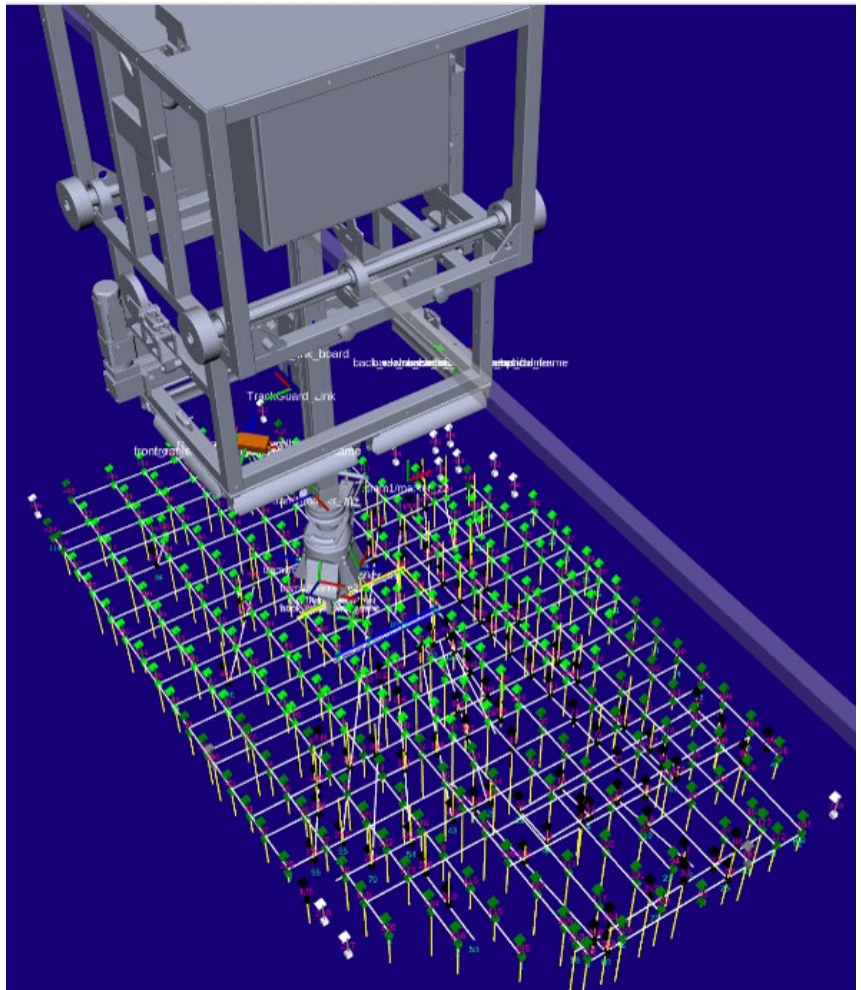



TyBOT Reference Videos

Reference Videos



TyBOT Walkthrough

This video covers basic walkthrough procedures for TyBOT.



Initial TyBOT Setup



Belly Box Functions

Learn the basic operational and safety functions of the TyBOT belly box.

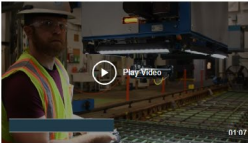

Installing the Tie Module

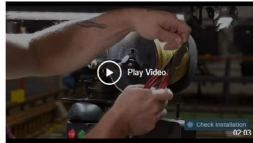

Replenishing a Tie Wire Spool

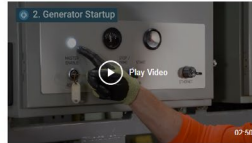

Generator Startup & Shutdown



Training

Comprehensive Training Program

ACR offers training to ensure smooth and successful use of TyBOT. For upskilling your crew, ACR provides certifications in Level I: Basic Operations, Level II: Advanced Operations and Project Management. These programs equip your team with the knowledge and skills necessary to confidently configure, mobilize, and deploy TyBOT from start to finish.





ACR BOTs Platform

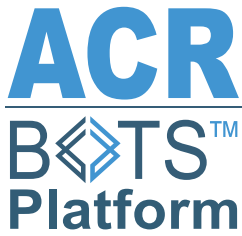

The ACR BOTs Platform offers customers a comprehensive, open-access portal with a range of valuable features.

The field data and analytics section provides cloud-based access for real-time monitoring and management of BOT Fleets, including productivity metrics, fault notifications, and statistics. It also offers automatic 24/7 monitoring with proactive alerts to the ACR support team, and up to six months of productivity and activity data that can be easily exported for internal reporting.

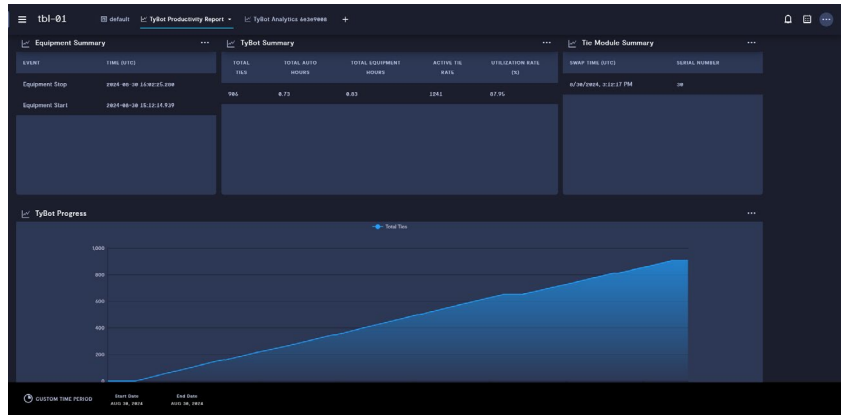

The productivity reports include telemetric data such as

- Tie Counts
- Active Tying Hours
- Total Equipment Hours
- Active Tie Rate
- Equipment Utilization Rate
- Tie Module Swap Time
- Tie Module Serial Number and Faults
- Linear Footage Travelled & Tied

Additionally, the customer service portal provides tailored solutions for deployment support, including Project Takeoff Requests, the TyBOT Configuration Calculator, a TyBOT Lift Plan Repository, and requests for support, maintenance, or new features. Users can also manage their accounts with tools for billing, licenses, subscriptions, asset management, and training records, as well as access a comprehensive knowledge base with owner and training manuals, plus reference cards.

The TyBOT Service and Support Department is staffed with professional service personnel who are available to provide both pre-deployment support as well as on-the-job technical assistance whenever needed.

Contact Us!

Office Phone: 412-756-3360
Email: sales@constructionrobots.com

Address: 3812 William Flinn Hwy
Building 1, Suite 400
Allison Park, PA 15101